

KOMPSAT-5 PRODUCT SPECIFICATIONS

Standard Products Specifications

Fair Access to Space

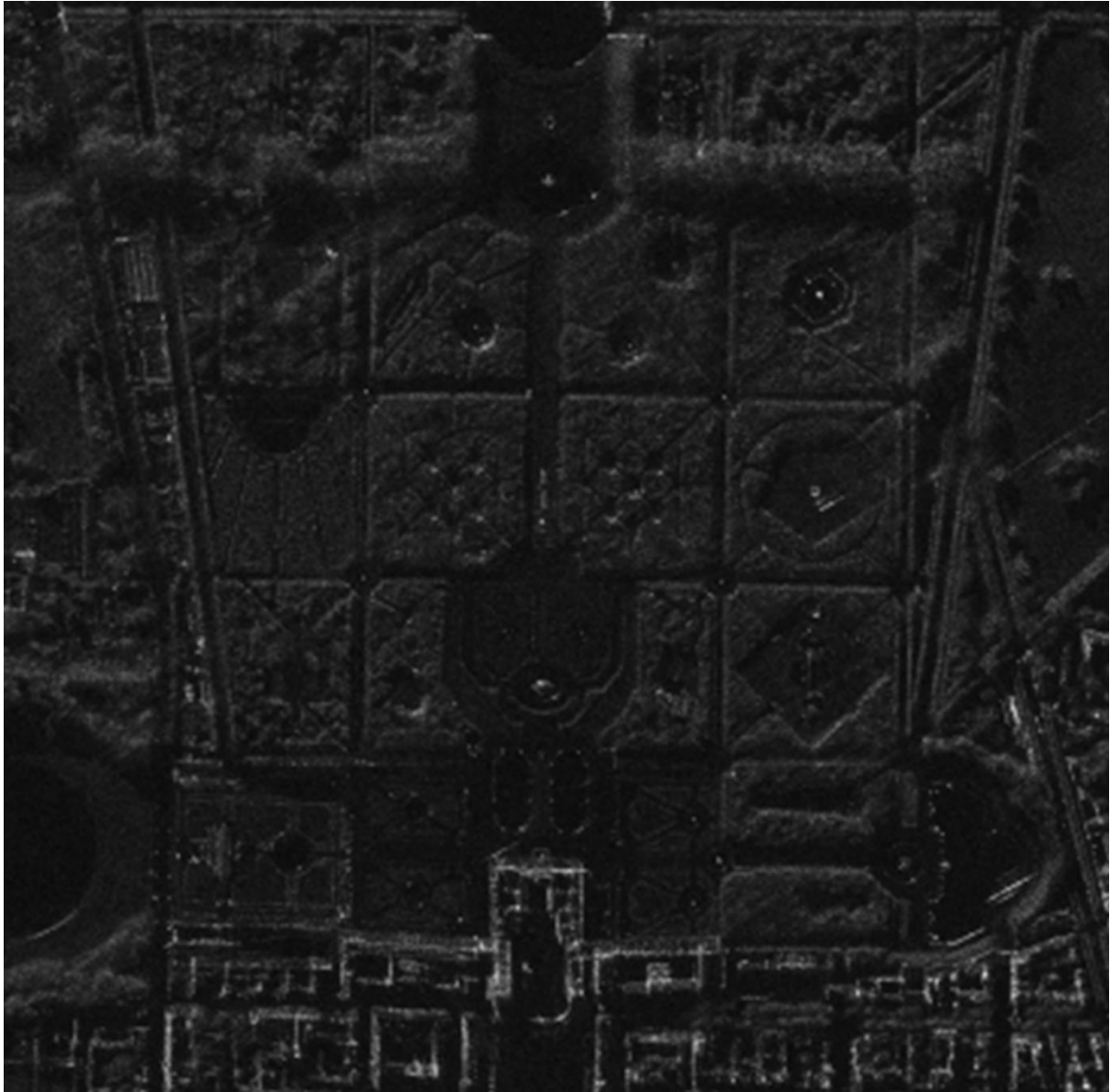

Palace of Versailles, France

Version 1.2
July, 2015

KOREA AEROSPACE RESEARCH INSTITUTE
SI IMAGING SERVICES Co., LTD

KARI
KOREA AEROSPACE RESEARCH INSTITUTE

SIIS

Contents

Table of Contents

1. KOMPSAT-5 SAR INSTRUMENT OVERVIEW	3
1.1 High Resolution Modes	4
1.2 Standard Modes	5
1.3 Wide Swath Modes	6
2. PROCESSING LEVELS OVERVIEW	7
2.1 Processing Level 0	10
2.1.1 RAW_B Product	11
2.2 Processing Level 1A	12
2.2.1 SCS_B and SCS_A Products	12
2.2.2 SCS_U and SCS_W Products	14
2.3 Processing Level 1C	14
2.3.1 GEC Products	15
2.3.2 WEC Products	15
2.4 Processing Level 1D	15
2.4.1 GTC Products	16
2.4.2 WTC Products	16
2.5 Auxiliary SDOUT Products	16
3. PRODUCTS OVERVIEW	18
3.1 High Resolution Mode Products	19
3.2 Enhanced High Resolution Mode Products	21
3.3 Ultra High Resolution Mode Products	23
3.4 Standard Mode Products	25
3.5 Enhanced Standard Mode Products	27
3.6 Wide Swath Mode Products	29
3.7 Enhanced Wide Swath Mode Products	31
4. OUTPUT FORMAT DESCRIPTION	34
4.1 Format Overview	34
4.1.1 HDF5 Groups	35
4.1.2 HDF5 Datasets	36
4.1.3 HDF5 Attributes	39
4.2 Products Organization	40
4.2.1 Constituent	40
4.2.2 Naming Convention	40
4.2.3 Hierarchies organization	42
4.2.4 Quick Look	50
4.2.5 Ancillary information organization	51
4.2.6 Data storage policy	52
5. REGULATION GOVERNING IMAGE DISTRIBUTION	53
5.1 Copyright	53
5.2 General Terms of Sale	53
5.3 Permitted Uses	54
5.4 Prohibited Uses	55
6. LICENSING	56
7. WARRANTY INFORMATION	57

1. KOMPSAT-5 SAR INSTRUMENT OVERVIEW

KOrea Multi-Purpose SATellite (KOMPSAT-5, hereafter) mission objectives are the provision of SAR images for Geographic Information Systems applications, and the Korean national environment and disaster monitoring System. The mission orbit is circular and the satellite altitude is 550 Km.

The KOMPSAT-5 SAR payload includes X-band (9.66 GHz) Synthetic Aperture Radar with a fixed antenna capable of electronic steering both in the azimuth and the elevation planes.

The elevation steering capabilities, allows defining an access region spanning approximately from 18.3° up to 49.0° in terms of the corresponding off-nadir angle (20° - 55° incidence angle @ 550 Km). Such range includes one nominal access spanning approximately from 18.3° up to 40.6° in terms of the corresponding off-nadir angle (20° - 45° incidence angle @ 550 Km) in which nominal performance are granted.

The SAR is designed to implement different types of Image Operation Mode that are briefly detailed in the following paragraphs.

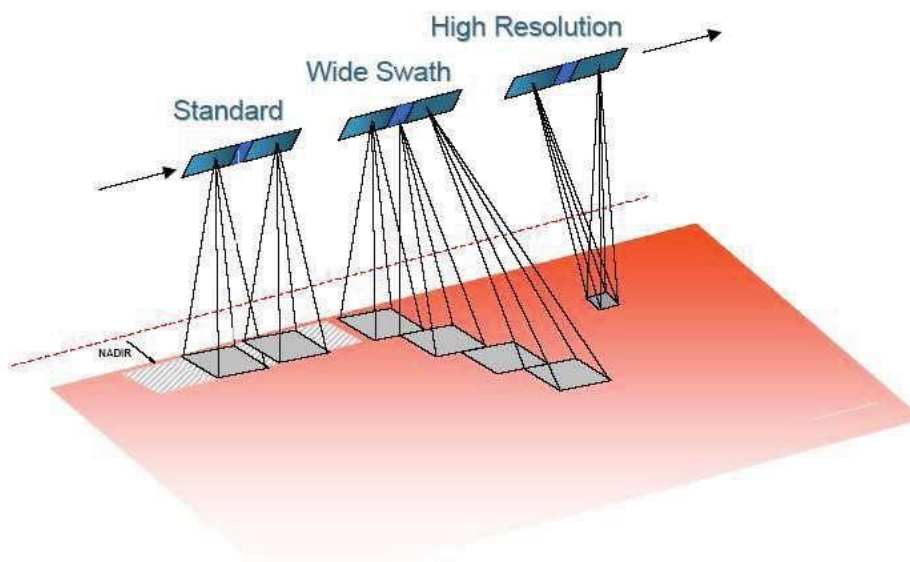

Figure 1-1 Measurement Mode

The SAR is capable of operating in three measurement modes: Standard Modes, High Resolution Modes and Wide Swath Modes. Each mode provides different

characteristics in terms of ground sample distance (i.e. geometrical resolution) and swath-width.

The “K5 System Enhanced” foresees the enhancement of SAR P/L with four additional operative modes:

- EH : Enhanced High Resolution mode
- UH : Ultra High Resolution mode
- ES : Enhanced Standard mode
- EW : Enhanced Wide Swath mode.

Image Operation Modes are briefly detailed in the following paragraphs.

1.1 High Resolution Modes

In these imaging modes the antenna is steered (in the azimuth plane) during the overall acquisition time in order to illuminate the required scene for a time period longer than the one of the standard strip side view. This increases the length of the synthetic antenna and therefore the azimuth resolution. Such improvement of the radar performance is paid by a loss of azimuth coverage. For the achievement of a range resolution comparable with the azimuth one, a chirp bandwidth less than or equal to 240 MHz is requested hence, implying the need of de-chirping of the received echo in order to reduce the downlink data rate. In such configuration the acquisition is limited in the azimuth direction due to the technical constraints deriving from the azimuth antenna pointing.

In High Resolution modes, the spot extension is achieved by a steering scheme, which requires the center of the beam steering to be located beyond the center of the imaged spot.

The electronic steering scheme, allows increasing the observed Doppler bandwidth for each target, though the instantaneous footprint is however interested by a sliding effect in the azimuth direction.

In the following a brief summary of the main imaging characteristics of the High Resolution Modes is given.

- HR: High Resolution Mode

It allows achieving 5 Km of swath width in the overall Access Region, the resolution is equal to 1m in the azimuth direction, and while it is variable in the range (1 m of range resolution is guaranteed at 45° of incidence angle).

- EH: Enhanced High Resolution Mode

The Enhanced High Resolution mode has been conceived in order to provide as much as possible a uniform resolution (i.e. 1 m) in the range direction. Due to H/W characteristics, only in a reduced part of the access region is possible to achieve a range resolution better than 1m.

- UH: Ultra High Resolution Mode

The Ultra High Resolution mode has been conceived in order to improve the range and azimuth resolution up to 0.85m. Due to H/W characteristics, only in a reduced part of the access region is possible to achieve a range resolution better than 1m.

1.2 Standard Modes

These imaging modes are obtained by pointing the antenna along a fixed direction with respect to the flight platform path. The antenna footprint covers a strip on the illuminated surfaces as the platform moves and the system operates. In such configuration the acquisition is performed on a continuous strip on the ground, hence it is virtually unlimited in the azimuth direction, but the current maximum SAR instrument duty cycle is 120 s.

In this mode the radar Tx/Rx configurations are time invariant, allowing receiving from each ground scatterer the full Doppler bandwidth allowed by the azimuth aperture of the antenna beamwidth.

In the following a brief summary of the main imaging characteristics of the Standard Modes is given.

- ST: Standard Mode

It allows achieving 30 Km of Swath in the most of the Access region at a variable resolution. In particular this mode allows achieving a resolution of 3m @ 45° and a resolution between 8m ÷ 4m over the largest part of the access region.

- ES: Enhanced Standard Mode

The Enhanced Standard mode has been conceived in order to improve the range resolution by exploiting the characteristics of the 120MHz IF filter, which can be used with a bandwidth greater than 120 MHz. At this aim a new mode at 2.5m of range resolution, has been designed.

1.3 Wide Swath Modes

This imaging mode allows larger swath in range with respect to the Standard one, but with a less spatial resolution. Larger range swaths are obtained by periodically stepping the antenna beam to neighbouring sub-swaths. In this mode only a part of the synthetic antenna length is available in azimuth and consequently the azimuth resolution is reduced. In such configuration the acquisition is performed in adjacent strip mode, hence it is virtually unlimited in the azimuth direction.

In the Wide Swath Mode, some elementary beams have been defined depending on the selected PRF ambiguity number and the acquisition incidence angle. Each configuration represents one of the subswaths that properly combined will cover the required total ground swath.

In the following a brief summary of the main imaging characteristics of the Wide Swath Modes is given.

- WS: Wide Swath Mode

It allows achieving total swath width between 90 and 120 Km in the nominal access region and a ground sample distance at 1 Look at 20 meters.

- EW: Enhanced Wide Swath Mode

The EW mode is focused on improving the radiometric resolution by implementing a dramatic increase of range resolution (20 m → 5 m) in order to apply a multi-look technique at image processing time (4 looks) which allows better image uniformity.

2. PROCESSING LEVELS OVERVIEW

SAR Standard product consists of SAR signal data or SAR image (originated by standard processing of the signal data) distributed on magnetic, optical or electronic media.

The standard processing of the KOMPSAT-5 SAR data has been thought to be as much as possible aligned with the definition deriving from literature.

If some alternative approach has been in some case adopted for the product specification, it has been however oriented to add value to the output data, preserving in any case the possibility for the final user to remove the effects of the additional non-standard processing applied to the data. Implementation of such policy will be better detailed in the following sections.

KOMPSAT-5 products may be classified according to the following basic features:

- instrument mode
- instrument configuration to be appropriately selected within each mode according to the desired access area and acquisition technical constraints
- The level of processing that has been applied to the data.

The KOMPSAT-5 SAR processors implement four levels of standard processing (from 0 up to level 1D), which a specific output product corresponds to. More than one product can correspond to each processing level:

- a product obtained by a basic processing will be in the following referred with the suffix <A> and ;
- a product obtained by a dedicated processing will be in the following referred with the suffixes <U> and <W>;

The following table summarizes the feature of the KOMPSAT-5 SAR Standard Products, which can be considered applicable independently on the instrument mode:

Proc. Lev.	Code	Sample Information	Projection
0	RAW_B	In-Phase and Quadrature of the echoed data with annexed Noise and Periodic Calibration measurements	Time ordering organization within pulse and between pulses
1A	SCS_B	Single Look Complex	Slant Range / Azimuth (Zero-Doppler)
	SCS_U		
	SCS_A		
	SCS_W		
1C	GEC_B	Geocoded Earth Ellipsoid	UTM, EGM96 EQPOT Surface
	GEC_A		
	GEC_W		
	WEC_B	Geocoded Earth Ellipsoid	GEOG, EGM96 EQPOT Surface
	WEC_A		
	WEC_W		
1D	GTC_B	Geocoded Earth Terrain	UTM, DEM + EGM96 EQPOT Surface
	GTC_A		
	GTC_W		
	WTC_B	Geocoded Earth Terrain	GEOG, DEM + EGM96 EQPOT Surface
	WTC_A		
	WTC_W		

Table 2-1 List of SAR Standard Products

The following table summarizes the data types to be used for storage of the data layers of the KOMPSAT-5 SAR Standard Products, independently on the SAR operation mode.

Product	Dataset	Sample Format	Bits per Sample	Samples per Pixel	Type Represent.	
RAW_B	Echo Data Noise Data CAL Data Replica	byte	8	2	Little Endian	
SCS_B SCS_U	Focused data	int 16 bit	16	2	Little Endian	
SCS_A SCS_W		*float 16 bit	16	2	Little Endian	
GEC_B WEC_B	Signal Amplitude	int 16 bit	16	1	Little Endian	
GEC_A WEC_A GEC_W WEC_W		*float 16 bit	16	1	Little Endian	
GTC_B WTC_B		Backscattering coefficient	int 16 bit	16	1	Little Endian
GTC_A WTC_A GTC_W WTC_W			*float 16 bit	16	1	Little Endian

* A 16bit float, so called FAB16, is used for HDF float products and standard 32bit float is used for GeoTiff .

Table 2-2 Data types for SAR Standard Products

The float 16 bit sample format is the operational baseline due to its wider dynamic range, smaller amplitude and phase errors respect to integer 16 bit data format, as shown below:

16 bit Integer

- dynamics [0,+96] dB signed
- dynamics [0,+90] dB unsigned
- accuracy [0,1] dB
- phase errors [0,2]°

16 bit Float

- dynamics [-66,+126] dB
- accuracy < 0.005 dB
- phase errors < 0.03°

KOMPSAT-5 provides float products in HDF format in order to deliver better dynamic range, accuracy and phase error.

Peculiarities of processing levels, independently on the instrument mode are given in the following sections.

2.1 Processing Level 0

The Level 0 product include a set of annotations, which detail its features in terms of:

- Time Correlation Data
- Sensor Parameters
- Orbital and attitude data
- Calibration data
- Localization info
- Raw data quality statistical parameters

It's worth stating that parameters for the internal calibration of the RAW data (that is the channels' bias, imbalance and non-orthogonality) are evaluated but not applied, in order to leave the data unchanged as much as possible.

2.1.1 RAW_B Product

The RAW product contains for each sensor acquisition mode the unpacked echo data in complex in-phase and quadrature signal (I and Q) format.

It is originated starting from the following input data:

- SAR Level 0 data file
- Satellite auxiliary data
- Orbital, attitude and pointing data (only for generation of attributes)

The only processing performed to the downlinked X-band raw signal data is:

- the frame synchronization at byte level, which consists in the analysis within the CCSDS data array stream in order to find out the SYNC pattern (synchronization 16 bit word) and supplementary secondary header constant bit fields. This allows the further CCSDS packet structure extraction
- removal of the data overstructure due to the CCSDS on-board to ground transmission protocol
- data decompression in the case the BAQ algorithm has been used on board to pack the data in order to reduce the downlink rate
- re-assembly of the Packet Data Field into contiguous radar range lines in increasing time order (duplicated range lines are discarded), by zero filling of the missing echo lines or missing echo blocks
- evaluation of statistics on the RAW data
- data formatting into the output format.

The RAW product includes data acquired in each single Instrument Mode, depending on the operation of the SAR instrument during the data reception or recording period. A RAW product will not ever combine data from more than one Instrument Mode, which are always packaged as two separate products. A RAW product must be SAR processed before it can be displayed as imagery.

Finally the product includes the QLK dataset which represent a raw data quick look (e.g. a down-sampled detected raw data array).

2.2 Processing Level 1A

The SCS product will include a set of attributes, which detail its features in terms of:

- Time Correlation Data
- Sensor Parameters
- Orbital and attitude data
- Calibration data
- Localization info
- Processing parameters
- Raw data quality statistical parameters
- Product Confidence Data
- Doppler Parameters (Doppler Centroid, Doppler Rate)

Additional considerations depending on the instrument mode need to be done

2.2.1 SCS_B and SCS_A Products

The SCS product contains for each sensor acquisition mode the focused data in complex format, in slant range and zero Doppler projection.

According to Table 5-2 SCS_B and SCS_A products have different sample format but the basic common processing features are:

The basic processing features characterizing the SCS_B product are:

- compensation of the transmitter gain and receiver attenuation
- internal calibration on the RAW data in terms of:
 - unbiasing
 - compensation of gain imbalance
 - compensation of non-orthogonality of I and Q channels
- the data focusing according to algorithm depending on the specific instrument
- weighted processing is performed with application of cosine-like windowing, so obtaining the maximum performances of the IRF features in terms of PSLR, ISLR, SSLR to the detriment of spatial resolution;
- radiometric equalization of the complex image in terms of:
 - compensation of the range spreading loss

- rescaling with respect to a reference slant range in order to not alter the dynamic of the output product

Data are processed at full range and azimuth resolution; hence any multilook processing isn't applied.

Concerning with the radiometric equalization of the single-look products, though it is considered on optional step and is explicitly to be avoided by some literature at the processing Level 1A, it has been taken into consideration in order to distribute to the users community a class of products having minimized the mis-calibration (both within scene and across swaths) originated by the SAR geometry acquisition. Moreover, to preserve the reversibility of the equalization process, an approach based on the use of a mathematical reference surface such as the ellipsoid has been selected for the compensation of the incidence angle and for the estimation and application of the range antenna pattern.

Therefore, enhanced processing based on the usage of DEM for the compensation of the incidence angle has been considered out of scope of this processing level.

This choice also derives from the considerations that usage of DEM for radiometric correction at standard processing level can introduce worsening effects on image calibration under the following conditions:

- if the DEM accuracy were of poor quality
- if problems on POD module occurred, due to on-board instruments or to data post-processing
- if the SAR image were affected by a not compensated time shift (both slow and fast time) that imply a wrong product localization on ground
- if a failure in the Doppler estimation occurred, hence implying a wrong product localization on ground

It's worth stating that the value of the calibration constant that allows converting the information of the image sample to backscattering coefficient is appended to the distributed product but not applied to it, considering this step as matter of backscattering product origination. For that reason, the product performances listed

in sections 4 (Output Format Description) that strictly depends on the measure on the image of the backscattering coefficients (radiometric accuracy, radiometric linearity, radiometric stability, local radiometric stability), have to be considered valid supposing that the quality control procedure take care of the application on the examined image of the annotated calibration constant.

2.2.2 SCS_U and SCS_W Products

An optional processing of Level 1A can be requested, differing from that one of the SCS_B product because of an unweighted processing is performed that is any windowing isn't applied on the processed bandwidth.

This processing level is thought to originate, by an approach as much conservative as possible, the focused representation of the raw signal echoed by the observed scene, in order to not change the data for higher processing levels.

For that reason, unweight processing is performed on raw data, so obtaining the maximum performances in terms of spatial resolution to the detriment of the IRF features.

For the same reason, any radiometric calibration (with the exception of the range spreading loss) isn't applied during the processing, postponing this step to optional or higher processing levels.

2.3 Processing Level 1C

The product will include a set of annotations, which detail its features in terms of:

- Time Correlation Data
- Sensor Parameters
- Orbital and attitude data
- Calibration data
- Localization info
- Processing parameters (including that one's specific to multilooking)
- Raw data quality statistical parameters
- Product Confidence Data
- Doppler Parameters (Doppler Centroid, Doppler Rate)
- Geolocation Parameters

Additional considerations depending on the instrument mode need to be done

2.3.1 GEC Products

The GEC product contains for each sensor acquisition mode the focused data, detected, geolocated on the reference ellipsoid and represented in cartographic projection (UTM or UPS depending on the Scene Center). Any geometric or radiometric correction derived by usage of terrain model isn't applied to this product.

The basic processing features characterizing the GEC_B product are:

- the same one's previously detailed for the generation of the SCS_B product (including radiometric equalization with the usage of the ellipsoid for the estimation of antenna pattern and incidence angle)
- multilooking and detection as specified for DGM product
- for Wide Swath mode only, subswath mosaicking and calibration constant equalization as specified for DGM product
- the map projection on the ellipsoid

The data shall be aligned with the north direction. The area of the product, outside the SAR sensed image data, shall be filled with invalid value because of the rotation to align with North. GEC_B, GEC_A, GEC_W are projected in UTM.

2.3.2 WEC Products

WEC_B, WEC_A, WEC_W products have the same features of GEC products but for GEOG (geographical coordinates system) projection.

2.4 Processing Level 1D

The product includes a set of annotations which detail its features in terms of:

- Time Correlation Data
- Sensor Parameters
- Orbital and attitude data
- Calibration data
- Localization info
- Processing parameters (including that one's specific to multilooking)
- Raw data quality statistical parameters

- Product Confidence Data
- Doppler Parameters (Doppler Centroid, Doppler Rate)
- Geolocation Parameters

Additional considerations depending on the instrument mode need to be done

2.4.1 GTC Products

The GTC product contains for each sensor acquisition mode the focused data, fully calibrated with the usage of terrain model, detected, geolocated on a DEM and represented cartographic projection (UTM or UPS depending on the Scene Center). The planimetric accuracy of the product will depend on DEM accuracy.

The processing features characterizing the GTC_B product are similar to that one's listed for the processing Level 1C with the following differences:

- usage of DEM for the ground projection
- usage of DEM for the estimation/compensation of the range antenna pattern and incidence angle
- application of the calibration constant to derive the backscattering coefficient
Image is represented in dB scale.

Image is represented in dB scale. GTC_B, GTC_A, GTC_W are projected in UTM.

2.4.2 WTC Products

WTC_B, WTC_A, WTC_W products have the same features of GTC products but for GEOG (geographical coordinates system) projection.

2.5 Auxiliary SDOUT Products

In SDOUT folder following auxiliary products can be found:

- PNG QLK
- KML

PNG QLK is a synoptic of the entire datum, having a look to the image content and it is annexed to all SAR standard products. The quick look is originated by undersampling of the full resolution raster layer, obtained by a filter (realized by a kernel of configurable size) moving in the row and columns directions at steps derived by the ratios of the output and input spacing.

Following tables details features of the quick look layer.

Products	Sample Information	Projection
Lev. 0	Unfocused image, detected, extracted as down-sampled of the RAW data echoes.	N/A
Lev. 1A	The same sample information of the distributed product the quick look is annexed to, detected, undersampled both in range and azimuth direction with the configurable factors depending on the sensor mode.	Slant Range/Azimuth
Lev. 1C/1D	The same sample information of the distributed product the quick look is annexed to, undersampled both in range and azimuth direction with the configurable factors depending on the sensor mode.	UTM (-80 ≤ center latitude ≤ 84°) UPS (otherwise)

Table 2-3 Features of the Quick Look Layers

Dataset	Sample Format	Bits per Sample	Samples per Pixel	Type Represent.	Invalid Value
Quick Look annexed to the Full resolution product	Unsigned Integer	8	1	Little Endian	0

Table 2-4 Data type for Quick look layer

KML Keyhole Markup Language (KML) is an XML notation for expressing geographic annotation and visualization within Internet-based, two-dimensional maps and three-dimensional Earth browsers. KML is provided for Processing Levels 1C (approximate geographical coordinates) and 1D product (with exact geographical coordinates, Google Earth DEM).

3. PRODUCTS OVERVIEW

Processing levels detailed in chapter 2 applied to data acquired in all modes allowed by the KOMPSAT-5 SAR instrument, so obtaining the products listed in the following subsections.

The following table summarizes the reference applicable performance requirements:

K5 SAR Modes		Nominal Access Region	Extended Access Region	Swath Width	Full resolution Swath	Ground Sample Distance	NE σ_0
High Resolution	HR	$20^\circ \leq \theta \leq 45^\circ$	$45^\circ < \theta \leq 55^\circ$	≥ 5 Km	-	≤ 1 m	≤ -17 dBm ² /m ²
Enhanced High Resolution	EH	$40.9^\circ \leq \theta \leq 55^\circ$	$20^\circ \leq \theta < 40.9$	≥ 5 Km	≥ 3 Km	≤ 1 m	≤ -17 dBm ² /m ²
Ultra High Resolution	UH	$50.3^\circ \leq \theta \leq 55^\circ$	$46.3^\circ \leq \theta < 50.3$	≥ 5 Km	≥ 2.7 Km	≤ 0.85 m	≤ -16 dBm ² /m ²
Standard	ST	$20^\circ \leq \theta \leq 45^\circ$	$45^\circ < \theta \leq 55^\circ$	≥ 30 Km	-	≤ 3 m	≤ -17 dBm ² /m ²
Enhanced Standard	ES	$28.8^\circ \leq \theta \leq 55$	$20^\circ \leq \theta < 28.8^\circ$	≥ 30 Km	≥ 30 Km	≤ 2.5 m	≤ -17 dBm ² /m ²
Wide Swath	WS	$20^\circ \leq \theta \leq 45^\circ$	$45^\circ < \theta \leq 55^\circ$	≥ 100 Km	-	≤ 20 m	≤ -17 dBm ² /m ²
Enhanced Wide Swath	EW	$20^\circ \leq \theta \leq 55^\circ$	-	≥ 100 Km	≥ 100 Km	≤ 5 m	≤ -17 dBm ² /m ²

NOTE: the values of Ground Sample Distance are to be intended at 1 Look

Table 3-1 Overall Image Quality References

K5 SAR Modes		PSLR	ISLR	AAR	RAR	RA
High Resolution	HR	≤ -19 dB @ nom. acc. region	≤ -13 dB @ nom. acc. region	≤ -17 dB @ nom. acc. region	≤ -17 dB @ nom. acc. region	≤ 1 dB @ nom. acc. region
Enhanced High Resolution	EH	≤ -20 dB @ nom. acc. Region	≤ -15 dB @ nom. acc. Region	≤ -17 dB @ nom. acc. Region	≤ -16 dB @ nom. acc. Region	≤ 1 dB @ nom. acc. Region
Ultra High Resolution	UH	≤ -20 dB @ nom. acc. Region	≤ -15 dB @ nom. acc. Region	≤ -21 dB @ nom. acc. Region	≤ -16 dB @ nom. acc. Region	≤ 1 dB @ nom. acc. region
Standard	ST	≤ -19 dB @ nom. acc. Region	≤ -13 dB @ nom. acc. Region	≤ -17 dB @ nom. acc. Region	≤ -17 dB @ nom. acc. Region	≤ 1 dB @ nom. acc. Region

Enhanced Standard	ES	≤ -20 dB @ nom. acc. Region	≤ -15 dB @ nom. acc. Region	≤ -18 dB @ nom. acc. Region	≤ -10 dB @ nom. acc. Region	≤ 1 dB @ nom. acc. region
Wide Swath	WS	≤ -19 dB @ nom. acc. Region	≤ -13 dB @ nom. acc. Region	≤ -17 dB @ nom. acc. Region	≤ -17 dB @ nom. acc. Region	≤ 1 dB @ nom. acc. region
Enhanced Wide Swath	EW	≤ -20 dB @ nom. acc. region	≤ -15 dB @ nom. acc. region	≤ -25 dB @ nom. acc. region	≤ -11 dB @ nom. acc. region	≤ 1 dB @ nom. acc. Region

Table 3-2 IRF Characteristics

3.1 High Resolution Mode Products

The following standard products originated depending on the processing level from data acquired in High Resolution Mode.

Product name	Processing Level
HR-RAW_B	0
HR-SCS_A HR-SCS_B HR-SCS_U HR-SCS_W	1A
HR-GEC_A HR-GEC_B HR-GEC_W HR-WEC_A HR-WEC_B HR-WEC_W	1C
HR-GTC_A HR-GTC_B HR-GTC_W HR-WTC_A HR-WTC_B HR-WTC_W	1D

Table 3-3 High Resolution Product List

Next table summarizes the basic features for the KOMPSAT-5 products originated from data acquired in High Resolution Mode

	HR -RAW	HR –SCS	HR - GEC HR - GTC HR – WEC HR - WTC
Line Spacing (m)	-	~0.7	~0.35
Column Spacing (m)	-	~0.7	~0.35
Number of lines	12000~14000	~7500	16000~19000
Number of columns	11000~15000	5200~9000	16000~19000
Product Size (MB)	250~350	140~450	500~700

Table 3-4 High Resolution Product Features

Next table lists the quality specifications considering the instrument operation modes nominal parameters in the nominal access region for the KOMPSAT-5 High Resolution Mode focused products. Such quality performances are guaranteed under the assumption the scene acquisition is performed under instrument and platform nominal condition.

When applicable such performances have to be considered valid both in range and azimuth directions.

	HR-SCS_A HR-SCS_B	HR-SCS_U HR-SCS_W	HR-GEC_A,B HR-WEC_A,B	HR-GEC_U HR-WEC_U	HR-GTC_A,B HR-GTC_A,B	HR-GTC_U HR-GTC_U
Ground Range resolution (m)	≤ 1m					
Azimuth resolution (m)	≤ 1m					
PSLR (dB)	≤ -19 dB	≤ -13 dB	≤ -19 dB		≤ -19 dB	
ISLR (dB)	≤ -13 dB				≤ 1 dB	
Radiometric Accuracy (dB)	≤ 1 dB		≤ 1 dB		≤ 1 dB	
Geometric Conformity	10 ⁻³	10 ⁻³	10 ⁻³	10 ⁻³	10 ⁻³	10 ⁻³
Geolocation [m]	100	100	100	100	100	100

Table 3-5 High Resolution Mode Products Requirement

The following table, lists the processing conditions under which, the product requirements listed in the previous table should be verified. Nevertheless, such

parameters shall be considered as living one's up to the completion of the commissioning phase of each satellite.

	HR-SCS_A HR-SCS_B	HR-SCS_U HR-SCS_W	HR-GEC_A,B HR-WEC_A,B	HR-GEC_U HR-WEC_U	HR-GTC_A,B HR-GTC_A,B	HR-GTC_U HR-GTC_U
Processing nom. range looks	1	1	1	1	1	1
Processing nom. azimuth looks	1	1	1	1	1	1
Range Processing weighting factor	0.242	0	0.240	0	0.240	0
Azimuth Processing weighting factor	0.332	0	0.320	0	0.320	0
Range processed bandwidth (% of PBW)	100	100	100	100	100	100
Azimuth processed bandwidth (KHz)	8.5	8.5	8.5	8.5	8.5	8.5

Table 3-6 High Resolution Mode processing condition

3.2 Enhanced High Resolution Mode Products

The following standard products will be originated depending on the processing level from data acquired in Enhanced High Resolution Mode.

Product name	Processing Level
EH-RAW_B	0
EH-SCS_A EH-SCS_B EH-SCS_U EH-SCS_W	1A
EH-GEC_A EH-GEC_B EH-GEC_W EH-WEC_A EH-WEC_B EH-WEC_W	1C
EH-GTC_A EH-GTC_B EH-GTC_W EH-WTC_A EH-WTC_B EH-WTC_W	1D

Table 3-7 Enhanced High Resolution Mode Products List

Next table summarizes the basic features for the KOMPSAT-5 products originated from data acquired in Enhanced High Resolution Mode.

	EH -RAW	EH -SCS	EH - GEC EH - GTC EH - WEC EH - WTC
Line Spacing (m)	-	~0.7	~0.35
Column Spacing (m)	-	~0.7	~0.35
Number of lines	12000~14000	~7500	16000~19000
Number of columns	11000~15000	6000~7000	16000~19000
Product Size (MB)	250~350	180~220	500~700

Table 3-8 Enhanced High Resolution Product Features

Next table lists the quality specifications considering the instrument operation modes nominal parameters in the nominal access region for the KOMPSAT-5 Enhanced High Resolution Mode focused products. Such quality performances are guaranteed under the assumption the scene acquisition is performed under instrument and platform nominal condition.

When applicable such performances have to be considered valid both in range and azimuth directions.

	EH-SCS_A EH-SCS_B	EH-SCS_U EH-SCS_W	EH-GEC_A,B EH-WEC_A,B	EH-GEC_U EH-WEC_U	EH-GTC_A,B EH-GTC_A,B	EH-GTC_U EH-GTC_U
Ground Range resolution (m)	≤ 1m					
Azimuth resolution (m)	≤ 1m					
PSLR (dB)	≤ -20 dB	≤ -13 dB	≤ -20 dB		≤ -20 dB	
ISLR (dB)	≤ -15 dB				≤ 1 dB	
Radiometric Accuracy (dB)	≤ 1 dB		≤ 1 dB		≤ 1 dB	
Geometric Conformity	10 ⁻³	10 ⁻³	10 ⁻³	10 ⁻³	10 ⁻³	10 ⁻³
Geolocation [m]	100	100	100	100	100	100

Table 3-9 Enhanced High Resolution Mode Products Requirement

The following table, lists the processing conditions under which, the product requirements listed in the previous table should be verified. Nevertheless, such

parameters shall be considered as living one's up to the completion of the commissioning phase of each satellite.

	EH-SCS_A EH-SCS_B	EH-SCS_U EH-SCS_W	EH-GEC_A,B EH-WEC_A,B	EH-GEC_U EH-WEC_U	EH-GTC_A,B EH-GTC_A,B	EH-GTC_U EH-GTC_U
Processing nom. range looks	1	1	1	1	1	1
Processing nom. azimuth looks	1	1	1	1	1	1
Range Processing weighting factor	0.242	0	0.240	0	0.240	0
Azimuth Processing weighting factor	0.332	0	0.320	0	0.320	0
Range processed bandwidth (% of PBW)	100	100	100	100	100	100
Azimuth processed bandwidth (KHz)	8.5	8.5	8.5	8.5	8.5	8.5

Table 3-10 Enhanced High Resolution Mode processing condition

3.3 Ultra High Resolution Mode Products

The following standard products will be originated depending on the processing level from data acquired in Ultra High Resolution Mode.

Product name	Processing Level
UH-RAW_B	0
UH-SCS_A UH-SCS_B UH-SCS_U UH-SCS_W	1A
UH-GEC_A UH-GEC_B UH-GEC_W UH-WEC_A UH-WEC_B UH-WEC_W	1C
UH-GTC_A UH-GTC_B UH-GTC_W UH-WTC_A UH-WTC_B UH-WTC_W	1D

Table 3-11 Ultra High Resolution Mode Products List

Next table summarizes the basic features for the KOMPSAT-5 products originated from data acquired in Ultra High Resolution Mode.

	UH -RAW	UH -SCS	UH - GEC UH - GTC UH - WEC UH - WTC
Line Spacing (m)	-	~0.7	~0.35
Column Spacing (m)	-	~0.7	~0.35
Number of lines	14000~16000	~8500	16000~19000
Number of columns	11000~15000	6000~7000	16000~19000
Product Size (MB)	280~380	220~250	500~700

Table 3-12 Ultra High Resolution Product Features

Next table lists the quality specifications considering the instrument operation modes nominal parameters in the nominal access region for the KOMPSAT-5 Ultra High Resolution Mode focused products. Such quality performances are guaranteed under the assumption the scene acquisition is performed under instrument and platform nominal condition.

When applicable such performances have to be considered valid both in range and azimuth directions.

	EH-SCS_A EH-SCS_B	EH-SCS_U EH-SCS_W	EH-GEC_A,B EH-WEC_A,B	EH-GEC_U EH-WEC_U	EH-GTC_A,B EH-GTC_A,B	EH-GTC_U EH-GTC_U
Ground Range resolution (m)	≤ 0.85 m					
Azimuth resolution (m)	≤ 0.85 m					
PSLR (dB)	≤ -20 dB	≤ -13 dB	≤ -20 dB		≤ -20 dB	
ISLR (dB)	≤ -15 dB				≤ 1 dB	
Radiometric Accuracy (dB)	≤ 1 dB		≤ 1 dB		≤ 1 dB	
Geometric Conformity	10 ⁻³	10 ⁻³	10 ⁻³	10 ⁻³	10 ⁻³	10 ⁻³
Geolocation [m]	100	100	100	100	100	100

Table 3-13 Ultra High Resolution Mode Products Requirement

The following table, lists the processing conditions under which, the product requirements listed in the previous table should be verified. Nevertheless, such parameters shall be considered as living one's up to the completion of the commissioning phase of each satellite.

	UH-SCS_A UH-SCS_B	UH-SCS_U UH-SCS_W	UH-GEC_A,B UH-WEC_A,B	UH-GEC_U UH-WEC_U	UH-GTC_A,B UH-GTC_A,B	UH-GTC_U UH-GTC_U
Processing nom. range looks	1	1	1	1	1	1
Processing nom. azimuth looks	1	1	1	1	1	1
Range Processing weighting factor	0.242	0	0.240	0	0.240	0
Azimuth Processing weighting factor	0.332	0	0.320	0	0.320	0
Range processed bandwidth (% of PBW)	100	100	100	100	100	100
Azimuth processed bandwidth (KHz)	8.5	8.5	8.5	8.5	8.5	8.5

Table 3-14 Ultra High Resolution Mode processing condition

3.4 Standard Mode Products

The following standard products originated depending on the processing level from data acquired in Standard Mode.

Product name	Processing Level
ST-RAW_B	0
ST-SCS_A ST-SCS_B ST-SCS_U ST-SCS_W	1A
ST-GEC_A ST-GEC_B ST-GEC_W ST-WEC_A ST-WEC_B ST-WEC_W	1C
ST-GTC_A ST-GTC_B ST-GTC_W ST-WTC_A ST-WTC_B ST-WTC_W	1D

Table 3-15 Standard Mode Product List

Next table summarizes the basic features for the KOMPSAT-5 products originated from data acquired in Standard Mode.

	ST -RAW	ST -SCS	ST - GEC ST - GTC ST - WEC ST - WTC
Line Spacing (m)	-	~1.15	~1.15
Column Spacing (m)	-	~1.15	~1.15
Number of lines	25000~27000	21000~24000	38000~42000
Number of columns	12000~14000	10000~13000	30000~33000
Product Size (MB)	550~750	900~1200	2400~2700

Table 3-16 Standard Mode Product Features

Next table lists the quality specifications (considering the instrument operation modes parameters in the nominal access region) for the KOMPSAT-5 Standard Mode focused products. Such quality performances are guaranteed under the assumption the scene acquisition is performed under instrument and platform nominal condition.

When applicable such performances have to be considered valid both in range and azimuth directions

	ST-SCS_A ST-SCS_B	ST-SCS_U ST-SCS_W	ST-GEC_A,B ST-WEC_A,B	ST-GEC_U ST-WEC_U	ST-GTC_A,B ST-GTC_A,B	ST-GTC_U ST-GTC_U
Ground Range resolution (m)	≤ 3 m					
Azimuth resolution (m)	≤ 3 m					
PSLR (dB)	≤ -19 dB	≤ -13 dB	≤ -19 dB		≤ -19 dB	
ISLR (dB)	≤ -13 dB					
Radiometric Accuracy (dB)	≤ 1 dB		≤ 1 dB		≤ 1 dB	
Geometric Conformity	10 ⁻³	10 ⁻³	10 ⁻³	10 ⁻³	10 ⁻³	10 ⁻³
Geolocation [m]	100	100	100	100	100	100

Table 3-17 Standard Mode Products Requirement

The following table, lists the processing conditions under which, the product requirements listed in the previous table should be verified. Nevertheless, such parameters shall be considered as living one's up to the completion of the commissioning phase of each satellite.

	ST-SCS_A ST-SCS_B	ST-SCS_U ST-SCS_W	ST-GEC_A,B ST-WEC_A,B	ST-GEC_U ST-WEC_U	ST-GTC_A,B ST-GTC_A,B	ST-GTC_U ST-GTC_U
Processing nom. range looks	1	1	1	1	1	1
Processing nom. azimuth looks	1	1	1	1	1	1
Range Processing weighting factor	0.265	0	0.260	0	0.260	0
Azimuth Processing weighting factor	0.280	0	0.250	0	0.250	0
Range processed bandwidth (% of PBW)	100	100	100	100	100	100
Azimuth processed bandwidth (KHz)	3.1	3.1	3.1	3.1	3.1	3.1

Table 3-18 Standard Mode processing condition

3.5 Enhanced Standard Mode Products

The following standard products originated depending on the processing level from data acquired in Enhanced Standard Mode.

Product name	Processing Level
ES-RAW_B	0
ES-SCS_A ES-SCS_B ES-SCS_U ES-SCS_W	1A
ES-GEC_A ES-GEC_B ES-GEC_W ES-WEC_A ES-WEC_B ES-WEC_W	1C
ES-GTC_A ES-GTC_B ES-GTC_W ES-WTC_A ES-WTC_B ES-WTC_W	1D

Table 3-19 Enhanced Standard Product Features

Next table summarizes the basic features for the KOMPSAT-5 products originated from data acquired in Enhanced Standard Mode.

	ES -RAW	ES -SCS	ES - GEC ES - GTC ES - WEC ES - WTC
Line Spacing (m)	-	~1.85	~1.125
Column Spacing (m)	-	~1.85	~1.125
Number of lines	25000~27000	21000~24000	38000~42000
Number of columns	15000~17000	14000~16000	30000~33000
Product Size (MB)	700~900	1100~1400	2400~2700

Table 3-20 Enhanced Standard Mode Product Features

Next table lists the quality specifications considering the instrument operation modes nominal parameters in the nominal access region for the KOMPSAT-5 Enhanced Standard Mode focused products. Such quality performances are guaranteed under the assumption the scene acquisition is performed under instrument and platform nominal condition.

When applicable such performances have to be considered valid both in range and azimuth directions.

	ES-SCS_A ES-SCS_B	ES-SCS_U ES-SCS_W	ES-GEC_A,B ES-WEC_A,B	ES-GEC_U ES-WEC_U	ES-GTC_A,B ES-GTC_A,B	ES-GTC_U ES-GTC_U
Ground Range resolution (m)	≤ 2.5 m					
Azimuth resolution (m)	≤ 2.5 m					
PSLR (dB)	≤ -20 dB	≤ -13 dB	≤ -20 dB		≤ -20 dB	
ISLR (dB)	≤ -15 dB					
Radiometric Accuracy (dB)	≤ 1 dB		≤ 1 dB		≤ 1 dB	
Geometric Conformity	10 ⁻³	10 ⁻³	10 ⁻³	10 ⁻³	10 ⁻³	10 ⁻³
Geolocation [m]	100	100	100	100	100	100

Table 3-21 Enhanced Standard Mode Products Requirement

The following table, lists the processing conditions under which, the product requirements listed in the previous table should be verified. Nevertheless, such parameters shall be considered as living one's up to the completion of the commissioning phase of each satellite.

	ES-SCS_A ES-SCS_B	ES-SCS_U ES-SCS_W	ES-GEC_A,B ES-WEC_A,B	ES-GEC_U ES-WEC_U	ES-GTC_A,B ES-GTC_A,B	ES-GTC_U ES-GTC_U
Processing nom. range looks	1	1	1	1	1	1
Processing nom. azimuth looks	1	1	1	1	1	1
Range Processing weighting factor	0.265	0	0.260	0	0.260	0
Azimuth Processing weighting factor	0.250	0	0.200	0	0.200	0
Range processed bandwidth (% of PBW)	100	100	100	100	100	100
Azimuth processed bandwidth (KHz)	3.1	3.1	3.1	3.1	3.1	3.1

Table 3-22 Enhanced Standard Mode processing condition

3.6 Wide Swath Mode Products

The following standard products originated depending on the processing level from data acquired in Wide Swath Mode.

Product name	Processing Level
WS-RAW_B	0
WS-SCS_A WS-SCS_B WS-SCS_U WS-SCS_W	1A
WS-GEC_A WS-GEC_B WS-GEC_W WS-WEC_A WS-WEC_B WS-WEC_W	1C
WS-GTC_A WS-GTC_B WS-GTC_W WS-WTC_A WS-WTC_B WS-WTC_W	1D

Table 3-23 Wide Swath Product Features

Next table summarizes the basic features for the KOMPSAT-5 products originated from data acquired in Wide Swath Mode.

	WS –RAW	WS –SCS	WS - GEC WS - GTC WS – WEC WS - WTC
Line Spacing (m)	-	~12.5	~12.5
Column Spacing (m)	-	~11	~12.5
Number of lines	4X12000~15000	4X9000~11000	17000~20000
Number of columns	2600~29000	2400~2700	15000~18000
Product Size (MB)	260~300	280~320	190~220

Table 3-24 Wide Swath Product Features

Next table lists the quality specifications (considering the instrument operation modes parameters in the nominal access region) for the KOMPSAT-5 Wide Swath Mode focused products. Such quality performances are guaranteed under the assumption the scene acquisition is performed under instrument and platform nominal condition.

When applicable such performances have to be considered valid both in range and azimuth directions.

	WS-SCS_A WS-SCS_B	WS-SCS_U WS-SCS_W	WS-GEC_A,B WS-WEC_A,B	WS-GEC_U WS-WEC_U	WS-GTC_A,B WS-GTC_A,B	WS-GTC_U WS-GTC_U
Ground Range resolution (m)	≤ 20 m					
Azimuth resolution (m)	≤ 20 m					
PSLR (dB)	≤ -19 dB	≤ -13 dB	≤ -19 dB		≤ -19 dB	
ISLR (dB)	≤ -13 dB					
Radiometric Accuracy (dB)	≤ 1 dB		≤ 1 dB		≤ 1 dB	
Geometric Conformity	10 ⁻³	10 ⁻³	10 ⁻³	10 ⁻³	10 ⁻³	10 ⁻³
Geolocation [m]	100	100	100	100	100	100

Table 3-21 Wide Swath Mode Products Requirement

The following table, lists the processing conditions under which, the product requirements listed in the previous table should be verified. Nevertheless, such parameters shall be considered as living one's up to the completion of the commissioning phase of each satellite.

	WS-SCS_A WS-SCS_B	WS-SCS_U WS-SCS_W	WS-GEC_A,B WS-WEC_A,B	WS-GEC_U WS-WEC_U	WS-GTC_A,B WS-GTC_A,B	WS-GTC_U WS-GTC_U
Processing nom. range looks	1	1	1	1	1	1
Processing nom. azimuth looks	1	1	1	1	1	1
Range Processing weighting factor	0.240	0	0.240	0	0.240	0
Azimuth Processing weighting factor	0	0	0	0	0	0
Range processed bandwidth (% of PBW)	100	100	100	100	100	100
Azimuth processed bandwidth (KHz)	-	-	-	-	-	-

Table 3-26 Wide Swath Mode processing condition

3.7 Enhanced Wide Swath Mode Products

The following standard products will be originated depending on the processing level from data acquired in Enhanced Wide Swath Mode.

Product name	Processing Level
EW-RAW_B	0
EW-SCS_A EW-SCS_B EW-SCS_U EW-SCS_W	1A
EW-GEC_A EW-GEC_B EW-GEC_W EW-WEC_A EW-WEC_B EW-WEC_W	1C
EW-GTC_A EW-GTC_B EW-GTC_W EW-WTC_A EW-WTC_B EW-WTC_W	1D

Table 3-27 Enhanced Wide Swath Product Features

Next table summarizes the basic features for the KOMPSAT-5 products originated from data acquired in Enhanced Wide Swath Mode.

	EW –RAW	EW –SCS	WS - GEC WS - GTC WS – WEC WS - WTC
Line Spacing (m)	-	~12.5	~7.5
Column Spacing (m)	-	~2.66	~7.5
Number of lines	4X12000~15000	4X9000~11000	28000~33000
Number of columns	2600~29000	9600~10800	25000~30000
Product Size (MB)	260~300	1120~1280	300~370

Table 3-28 Enhanced Wide Swath Product Features

Next table lists the quality specifications considering the instrument operation modes nominal parameters in the nominal access region for the KOMPSAT-5 Enhanced Wide Swath Mode focused products. Such quality performances are guaranteed under the assumption the scene acquisition is performed under instrument and platform nominal condition.

When applicable such performances have to be considered valid both in range and azimuth directions.

	WS-SCS_A WS-SCS_B	WS-SCS_U WS-SCS_W	WS-GEC_A,B WS-WEC_A,B	WS-GEC_U WS-WEC_U	WS-GTC_A,B WS-GTC_A,B	WS-GTC_U WS-GTC_U
Ground Range resolution (m)	≤ 5 m					
Azimuth resolution (m)	≤ 20 m					
PSLR (dB)	≤ -20 dB	≤ -13 dB	≤ -20 dB		≤ -20 dB	
ISLR (dB)	≤ -15 dB					
Radiometric Accuracy (dB)	≤ 1 dB		≤ 1 dB		≤ 1 dB	
Geometric Conformity	10 ⁻³	10 ⁻³	10 ⁻³	10 ⁻³	10 ⁻³	10 ⁻³
Geolocation [m]	100	100	100	100	100	100

Table 3-29 Enhanced Wide Swath Mode Products Requirement

The following table, lists the processing conditions under which, the product requirements listed in the previous table should be verified. Nevertheless, such parameters shall be considered as living one's up to the completion of the commissioning phase of each satellite.

	EW-SCS_A EW-SCS_B	EW-SCS_U EW-SCS_W	EW-GEC_A,B EW-WEC_A,B	EW-GEC_U EW-WEC_U	EW-GTC_A,B EW-GTC_A,B	EW-GTC_U EW-GTC_U
Processing nom. range looks	1	1	1	1	1	1
Processing nom. azimuth looks	1	1	1	1	1	1
Range Processing weighting factor	0.240	0	0.240	0	0.240	0
Azimuth Processing weighting factor	0	0	0	0	0	0
Range processed bandwidth (% of PBW)	100	100	100	100	100	100
Azimuth processed bandwidth (KHz)	-	-	-	-	-	-

Table 3-30 Enhanced Wide Swath Mode processing condition

4. OUTPUT FORMAT DESCRIPTION

The data packaging organization adopted as distribution format for the standard products is HDF5. The support format detailed below will be used to store image layers and the relevant ancillary information, forming the output product to be distributed to the final user.

4.1 Format Overview

The HDF5 (Hierarchical Data Format) format and software, was developed and supported by NCSA (National Centre for Supercomputing Applications University of Illinois) since 1988 and is freely available.

It is used worldwide in many fields, including environmental science, the study of neutron scattering, non-destructive testing, and aerospace research. Scientific projects that use HDF include NASA's Earth Observing System (EOS), and the Department of Energy's Accelerated Strategic Computing Initiative (ASCI).

For more information or software the following link is available <http://hdf.ncsa.uiuc.edu>.

HDF5 files are organized in a hierarchical structure, with two primary structures:

- Groups, which are container structures which can hold datasets and other groups
- Datasets, which are multidimensional arrays of a homogeneous type

A grouping structure contains instances of zero or more groups or datasets, together with supporting metadata.

Any HDF5 group or dataset may have an associated attribute list. An HDF5 attribute is a user-defined HDF5 structure that provides extra information about an HDF5 object. Attributes are described in more detail below.

The hierarchical organization of the HDF5 format is graphically represented in Figure 4-1.

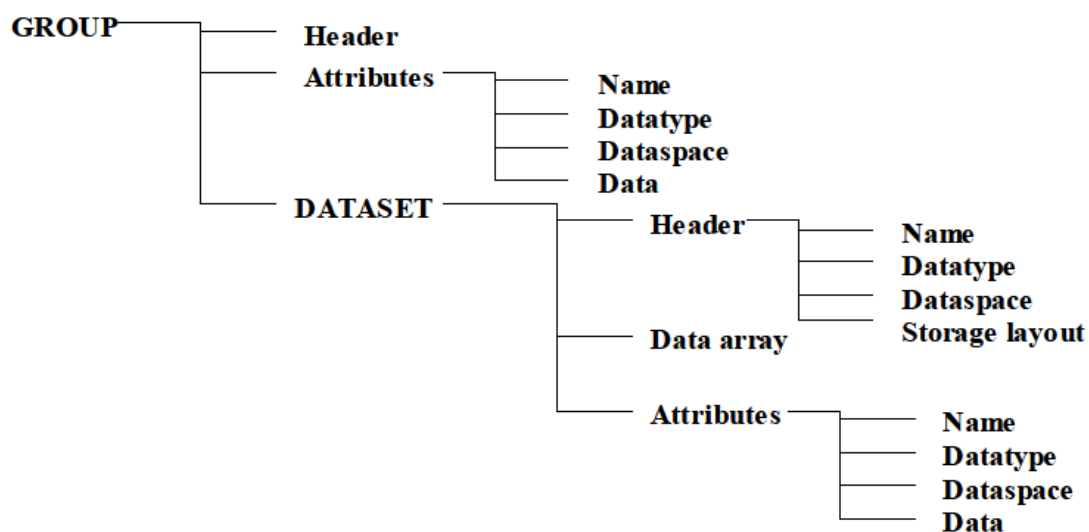

Figure 4-1: HDF5 organization

4.1.1 HDF5 Groups

An HDF5 group is a structure containing zero or more HDF5 objects. A group has two parts:

- A group header, which contains a group name and a list of group attributes.
- A group symbol table, which is a list of the HDF5 objects that belong to the group.

Working with groups and group members is similar in many ways to working with directories and files in UNIX. As with UNIX directories and files, objects in an HDF5 file are often described by giving their full (or absolute) path names.

/	Signifies the root group.
/foo	Signifies a member of the root group called foo.
/foo/zoo	Signifies a member of the group foo, which in turn is a member of the root group.

Any HDF5 group or dataset may have an associated *attribute list*. An HDF5 attribute is a userdefined HDF5 structure that provides extra information about an HDF5 object.

4.1.2 HDF5 Datasets

A dataset is a multidimensional array of data elements, together with supporting metadata. A dataset is stored in a file in two parts

- A header
- A data array.

The header contains information that is needed to interpret the array portion of the dataset, as well as metadata (or pointers to metadata) that describes or annotates the dataset. Header information includes the name of the object, its dimensionality, its number-type, information about how the data itself is stored on disk, and other information used by the library to speed up access to the dataset or maintain the file's integrity.

There are four essential classes of information in any header:

- Name
- Datatype
- Dataspace
- Storage layout

4.1.2.1 Name

A dataset name is a sequence of alphanumeric ASCII characters.

4.1.2.2 Datatype

HDF5 allows one to define many different kinds of datatypes. There are two categories of datatypes (*Atomic* datatypes and *Compound* datatypes). Atomic datatypes can also be system-specific, or *NATIVE*, and all datatypes can be *named*:

- **Atomic** datatypes are those that are not decomposed at the datatype interface level, such as integers and floats.
- **NATIVE** datatypes are system-specific instances of atomic datatypes.
- **Compound** datatypes are made up of atomic datatypes.

- **Named** datatypes are either atomic or compound datatypes that have been specifically designated to be shared across datasets.

Atomic datatypes include integers and floating-point numbers. Each atomic type belongs to a particular class and has several properties: size, order, precision, and offset. In this introduction, we consider only a few of these properties.

Atomic classes include integer, float, date and time, string, bit field, and opaque. (Note: Only integer, float and string classes are available in the current implementation.)

Properties of integer types include size, order (endian-ness), and signed-ness (signed/unsigned). Properties of float types include the size and location of the exponent and mantissa, and the location of the sign bit.

The datatypes that are supported in the current implementation are:

- Integer datatypes: 8-bit, 16-bit, 32-bit, and 64-bit integers in both little and big-endian format.
- Floating-point numbers: IEEE 32-bit and 64-bit floating-point numbers in both little and big-endian format.
- References.
- Strings.

NATIVE datatypes. Although it is possible to describe nearly any kind of atomic data type, most applications will use predefined datatypes that are supported by their compiler. In HDF5 these are called native datatypes. **NATIVE** datatypes are C-like datatypes that are generally supported by the hardware of the machine on which the library was compiled. In order to be portable, applications should almost always use the **NATIVE** designation to describe data values in memory.

The **NATIVE** architecture has base names that do not follow the same rules as the others. Instead, native type names are similar to the C type names.

A compound datatype is one in which a collection of simple datatypes are represented as a single unit, similar to a struct in C. The parts of a compound

datatype are called members. The members of a compound datatype may be of any datatype, including another compound datatype. It is possible to read members from a compound type without reading the whole type.

Named datatypes. Normally each dataset has its own datatype, but sometimes we may want to share a datatype among several datasets. This can be done using a named datatype. A named data type is stored in the file independently of any dataset, and referenced by all datasets that have that datatype. Named datatypes may have an associated attributes list. See Datatypes in the HDF User's Guide for further information.

4.1.2.3 Dataspace

A dataset dataspace describes the dimensionality of the dataset. The dimensions of a dataset can be fixed (unchanging), or they may be unlimited, which means that they are extendible (i.e. they can grow larger).

Properties of a dataspace consist of the rank (number of dimensions) of the data array, the actual sizes of the dimensions of the array, and the maximum sizes of the dimensions of the array. For a fixed-dimension dataset, the actual size is the same as the maximum size of a dimension.

A dataspace can also describe portions of a dataset, making it possible to do partial I/O operations on selections.

Given an n-dimensional dataset, there are currently four ways to do partial selection:

- Select a logically contiguous n-dimensional hyperslab.
- Select a non-contiguous hyperslab consisting of elements or blocks of elements (hyperslabs) that are equally spaced.
- Select a union of hyperslabs.
- Select a list of independent points.

Since I/O operations have two end-points, the raw data transfer functions require two dataspace arguments: one describes the application memory dataspace or subset thereof, and the other describes the file dataspace or subset thereof.

4.1.2.4 Storage layout

The HDF5 format makes it possible to store data in a variety of ways. The default storage layout format is contiguous, meaning that data is stored in the same linear way that it is organized in memory. Two other storage layout formats are currently defined for HDF5: compact, and chunked. In the future, other storage layouts may be added.

Compact storage is used when the amount of data is small and can be stored directly in the object header.

Chunked storage involves dividing the dataset into equal-sized "chunks" that are stored separately. Chunking has three important benefits.

It makes it possible to achieve good performance when accessing subsets of the datasets, even when the subset to be chosen is orthogonal to the normal storage order of the dataset.

It makes it possible to compress large datasets and still achieve good performance when accessing subsets of the dataset.

It makes it possible efficiently to extend the dimensions of a dataset in any direction.

4.1.3 HDF5 Attributes

Attributes are small named datasets that can be attached to one of the following structures:

- primary datasets
- groups
- named datatypes

Attributes can be used to describe the nature and/or the intended usage of a dataset or group. An attribute has two parts

- name
- value

The value part contains one or more data entries of the same data type.

When accessing attributes, they can be identified by name or by an index value. The use of an index value makes it possible to iterate through all of the attributes associated with a given object.

4.2 Products Organization

Specific data organization will be detailed to meet the storage needs of data acquired with all the instrument modes allowed by the KOMPSAT-5.

4.2.1 Constituent

There are four essential files

- Image data in hdf5 format(~.h5) or GeoTiff(~.tif)
- Ancillary in XML (~_Aux.xml)
- Browse image (~br.jpg)
- Thumbnail image (~_th.jpg)
- Quick Look Image(~_QL.png)

4.2.2 Naming Convention

The following naming convention will be used for the identification of the KOMPSAT-5 SAR Standard Products files

DIRECTORY

<K5>_<YYYYMMDDhhmmss>_<ttttt>_<nnnnn>_<o>_<MM><SS>_<PP>_<LLL>

IMAGE(HDF5)

<K5>_<YYYYMMDDhhmmss>_<ttttt>_<nnnnn>_<o>_<MM><SS>_<PP>_<YYY_Z>_<LLL>
.h5

IMAGE(GEOTIFF)

<K5>_<YYYYMMDDhhmmss>_<ttttt>_<nnnnn>_<o>_<MM><SS>_<PP>_<c>_<bb>_<Y
 YY_Z>_<LLL>.tif

IMAGE(BROWSE)

<K5>_<YYYYMMDDhhmmss>_<ttttt>_<nnnnn>_<o>_<MM><SS>_<PP>_<c>_<bb>_<Y
 YY_Z>_<LLL>_br.tif

IMAGE(THUMB)

<K5>_<YYYYMMDDhhmmss>_<ttttt>_<nnnnn>_<o>_<MM><SS>_<PP>_<c>_<bb>_<Y
 YY_Z>_<LLL>_th.tif

IMAGE(QUICK LOOK)

<K5>_<YYYYMMDDhhmmss>_<ttttt>_<nnnnn>_<o>_<MM><SS>_<PP>_<c>_<bb>_<Y
 YY_Z>_<LLL>_<YYY_Z>_<MM>_QL.png

The semantic of the variable sub-strings is reported in the following table:

Sub-string code	Meaning	Allowed values
<K5>	Identifier of the satellite that acquired the scene	K5 (KOMPSAT-5)
<YYYYMMDDhhmmss>	Sensing Start Time rounded to the closest integer second	YYYY = year MM = month DD = day of the month hh = hour mm = minute ss = second
<ttttt>	Processing offset	In millisecond
<nnnnn>	Number of Orbit	[00000..99999]
<o>	Identifier of the Orbit Direction	A = Ascending D = Descending
<MM>	Instrument Mode used during the acquisition	HR (High Resolution) EH (Enhanced High Resolution) UH (Ultra High Resolution) ST (Standard) ES (Enhanced Standard) WD (Wide Swath) EW (Enhanced Wide Swath)

<SS>	Identifier of the swath (or subswath combination in the case of Wide Swath mode) used for the data acquisition	[01-...-31] for HR Mode [01-...-31] for EH Mode [23-...-31] for UH Mode [01-...-19] for ST Mode [01-...-19] for ES Mode [01-...-05] for WS Mode [01-...-05] for EW Mode
<PP>	Polarizations used during the acquisition	HH = Horizontal Tx/Horizontal Rx VV = Vertical Tx/ Vertical Rx HV = Horizontal Tx/ Vertical Rx VH = Vertical Tx/ Horizontal Rx
<c>	Channel indicator I/Q for L1A GeoTiff	I or Q
<bb>	Sub-beam ID for L1A GeoTiff	[01..04]
<YYY_Z>	Product Type	Standard Products: RAW_B SCS_A SCS_B SCS_U SCS_W GEC_A GEC_B GEC_W WEC_A WEC_B WEC_W GTC_A GTC_B GTC_W WTC_A WTC_B WTC_W
<LLL>	Processing level	L1A L1C L1D

Table 4-1 File naming convention

4.2.3 Hierarchies organization

The HDF5 allows the hierarchical organization of the information to be stored.

In order to standardize the data organization and the access to the image layers stored by the HDF5 support format, each level of the HDF5 hierarchy has been

univocally assigned to the storage of a specific level of information of the SAR products according to the following scheme.

/ - Root group

Instrument Modes (Processing Level): All (0/1A/1C/1D)

For each Instrument Mode and processing level it includes:

- the attributes to be considered applicable to the whole acquisition / product, hence that are subswaths-independent
- one or more group named S<mm> detailed below
- zero or one dataset named MBI (Multi Beam Image) detailed below
- zero or one dataset named QLK (Quick Look) detailed below
- zero or one dataset named GIM (Geocoded Incidence Mask) detailed below

S<mm> groups

Instrument Modes (Processing Level): All (0/1A/1C/1D)

It includes:

- the attributes dependent on the specific subswath used within the full multi-beam swath in the case of Wide Swath mode and within the access area otherwise (for example the PRF)
- one or more dataset named B<nnn> detailed below
- zero or one dataset named SBI (Single Beam Image), in the case of Wide Swath modes, detailed below
- zero or one dataset named QLK (Quick Look) detailed below
- zero or one dataset CAL including all the ShortCal pulses acquired during the acquisition's sequence of the scene echoes.
- zero or one dataset REPLICIA including all the reconstructed replica chirp.
- zero or one dataset NOISE including all the Noise measures performed during the acquisition's sequence of the scene echoes.

In the case of HR/EH/UH/ST/ES products <mm> = 01. In the case of WS/EW products <mm> \in {01, 02, 03, 04} used in increasing order from the nearest subswath to the farthest one. Moreover, S01 group will always include the earliest acquired burst.

B<nnn> can be a group or dataset according to the following scheme:

B<nnn> dataset

Instrument Modes (Processing Level): All (0)

It includes:

- the attributes dependent on the time sequential data block (the burst) to be considered applicable for the acquired raw data (for example the Sensing Start Time)
- the data array with the raster layer.
- In the case of Standard and High Resolution products <nnn> = 001
- In the case of Wide Swath products <nnn> \in [001, 999] used in increasing order from the earliest acquired burst to the latest one. The same number of bursts will be always included in each S<mm> group of the distributed product.

B<nnn> group

Instrument Modes (Processing Level): All (1A/1C/1D)

It includes the attributes dependent on the time sequential data block (the burst) to be considered applicable for the acquired raw data (for example the Sensing Start Time)

Q<nnn> group

Instrument Modes (Processing Level): All (1C/1D)

It is used for FDBAQ decoding in Sentinel-1 CCSDS Data decoding

SBI dataset

Instrument Modes (Processing Level): HR/EH/UH/ST/ES (1A/1C/1D) and WS/EW (1A)

It includes

- the attributes dependent on the subswath used within the access area to be considered applicable for the distributed product (for example the Line Time Interval)
- one raster data array representing the product to be distributed

MBI dataset

Instrument Modes (Processing Level): WS/EW (1C/1D)

It includes

- the attributes dependent on the mosaicked full scene to be considered applicable for the distributed product (for example the Line Time Interval)
- one raster data array representing the range/azimuth mosaicked product to be distributed

QLK Dataset

Instrument Modes (Processing Level): All (0/1A/1C/1D)

It includes the quick look of the distributed product.

GIM Dataset

Instrument Modes (Processing Level): All (1D)

Dataset realized for future extension.

HEM Dataset

Instrument Modes (Processing Level): All (1D)

Dataset realized for future extension.

START group

Instrument Modes (Processing Level): All (0)

It includes the dataset of Calibration (CAL) and Noise (NOISE) measurements performed during the acquisition initialization sequence extracted from the downlinked RAW data

STOP group

Instrument Modes (Processing Level): All (0)

It includes the dataset of Calibration (CAL) and Noise (NOISE) measurements performed during the acquisition termination sequence extracted from the downlinked RAW data

NOISE dataset

Instrument Modes (Processing Level): All (0)

It includes the Noise data from the downlinked RAW data.

- The dataset START/NOISE (respectively STOP/NOISE), includes the Noise measurements performed during the acquisition Initialization (respectively Termination) sequence;
- The dataset /S<nn>/NOISE, includes all the Noise measures performed during the acquisition's sequence of the scene echoes

CAL dataset

Instrument Modes (Processing Level): All (0)

It includes the Calibration data from the downlinked RAW data. Three cases can be identified:

- the dataset /START/CAL, includes all the Calibration measurements (Tx1a, Tx1b and Rx performed on each row of the antenna plus an additional ShortCal pulse) performed during the acquisition's Initialization sequence;
- the dataset /STOP/CAL, includes all the Calibration measurements (Tx1a, Tx1b and Rx performed on each row of the antenna plus an additional ShortCal pulse) performed during the acquisition's Termination sequence;
- the dataset /S<nn>/CAL, includes all the ShortCal pulses acquired during the acquisition's sequence of the scene echoes.

REPLICA dataset

Instrument Modes (Processing Level): All (0)

It includes the replica chirp reconstructed from the calibration data included into the downlinked RAW data. It includes a number of lines equal to the number of measured ShortCal pulses

The hierarchical organization for each Instrument Mode and Processing Level is graphically represented in the following diagrams.

A not color filled structure



represents a HDF5 structure group.

A color filled structure

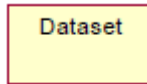

represents a generic HDF5 dataset including data array and the relevant attributes.

Suffixes <mm>/<nnn> between angular brackets indicates that the cardinality of the group/dataset is greater than one.

Following the Standard/High Resolution Modes Products HDF5 structures:

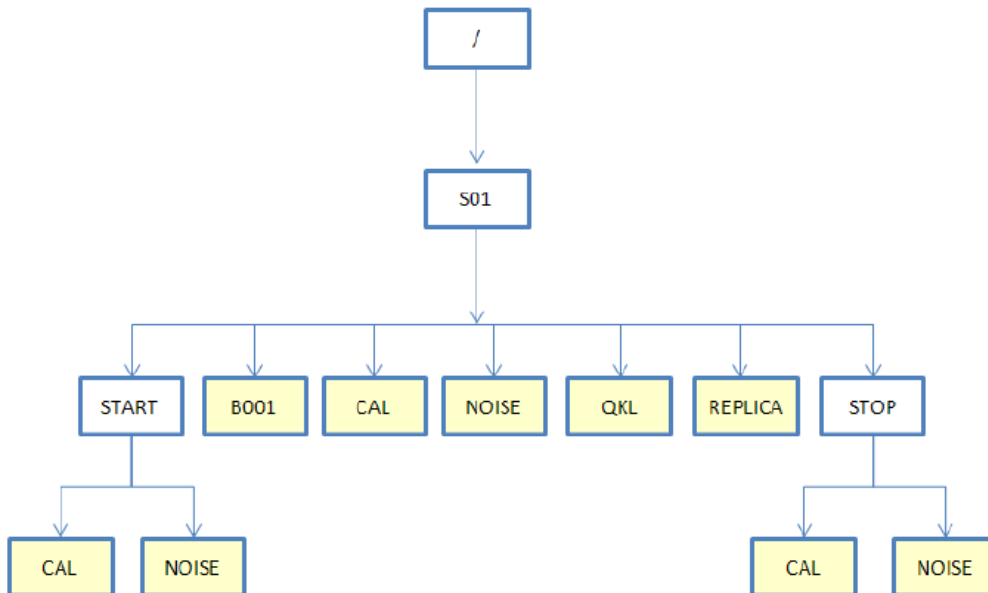

Figure 4-2: Standard/High Resolution Modes – Level 0 - RAW

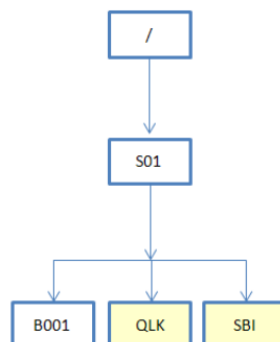

Figure 4-3: Standard/High Resolution Modes – Level 1A - SCS

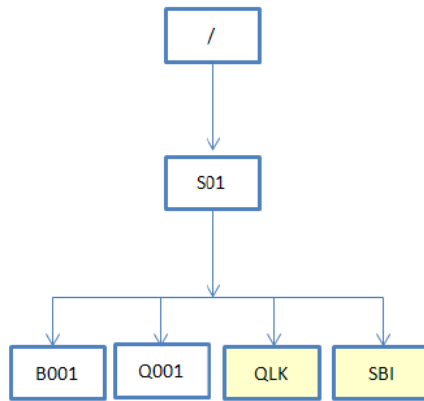

Figure 4-4: Standard/High Resolution Modes – Level 1C – GEC/WEC

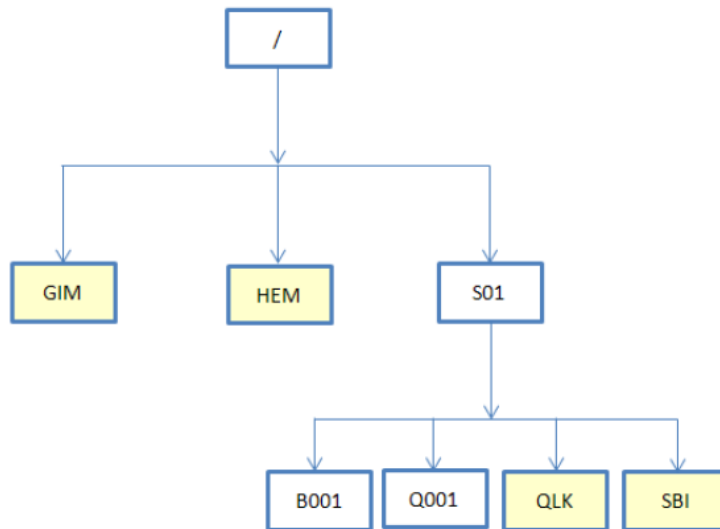

Figure 4-5: Standard/High Resolution Modes – Level 1D – GTC/WTC

Following the Wide Swath Modes Products HDF5 structures:

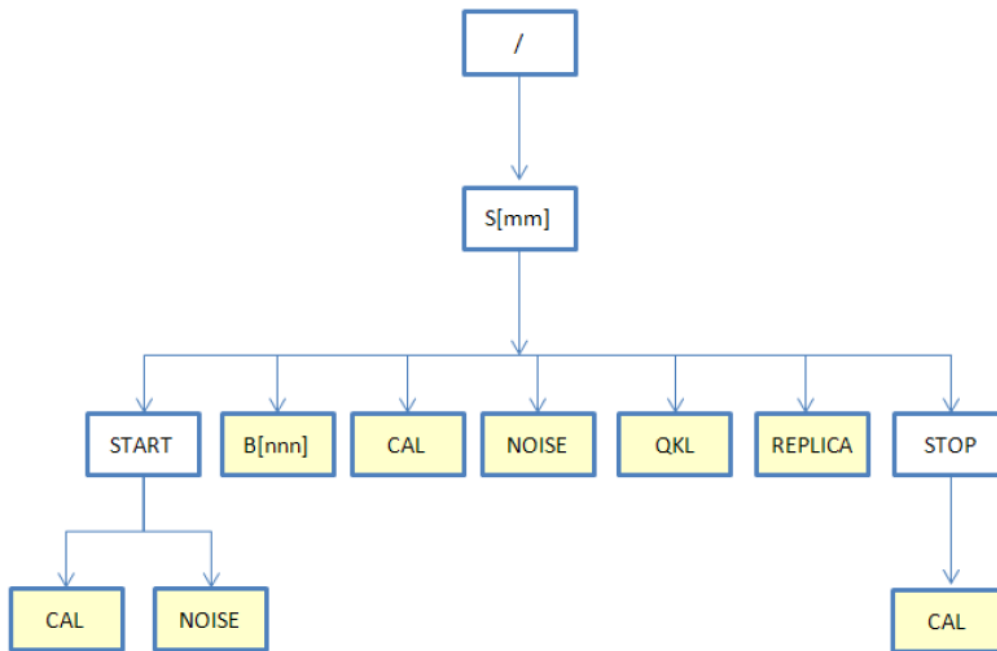

Figure 4-6: Wide Swath Modes – Level 0 – RAW

Please note that the Level 0 Wide Swath products presents the NOISE dataset of the START group in each subswath group (S<mm>) even if only for the first subswath (S<01>) this dataset will be populated according to the SAR Instrument design.

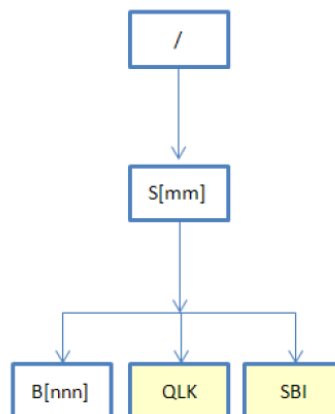

Figure 4-7: Wide Swath Modes – Level 1A – SCS

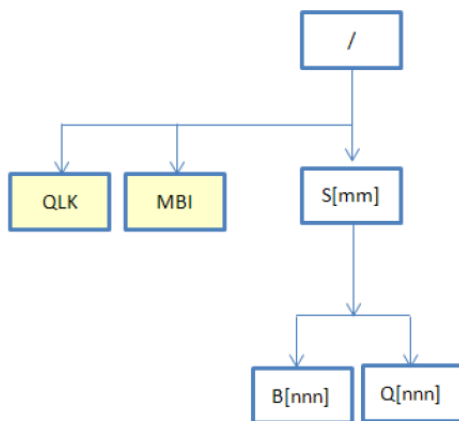

Figure 4-8: Wide Swath Modes – Level 1C – GEC/WEC

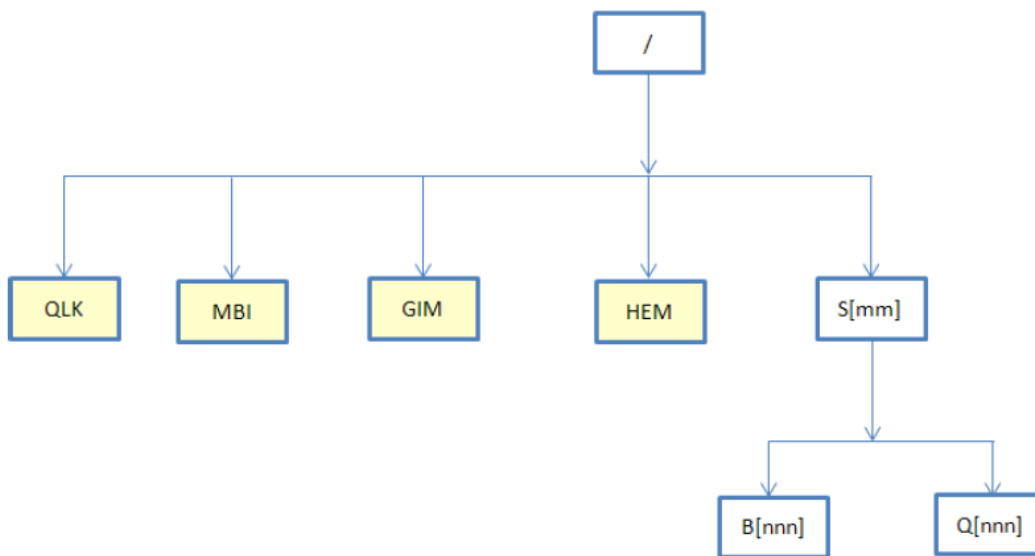

Figure 4-8: Wide Swath Modes – Level 1D – GTC/WTC

4.2.4 Quick Look

A synoptic of the entire datum allowing having a look to the image content is annexed to all SAR standard products. For product at processing level 1, the quick look is originated by undersampling of the full resolution raster layer, obtained by a filter (realized by a kernel of configurable size) moving in the row and column directions at steps derived by the ratios of the output and input spacing. Following tables details features of the quick look layer.

Products	Sample Information	Projection
Lev. 0	Unfocused image, detected, extracted as down-sampled of the RAW data echoes.	N/A
Lev. 1A	The same sample information of the distributed product the quick look is annexed to, detected, undersampled both in range and azimuth direction with the following factors depending on the sensor mode: High Resolution: 25 Standard: 30 Wide Swath: 15	Slant Range/Azimuth
Lev. 1C/1D	The same sample information of the distributed product the quick look is annexed to, undersampled both in range and azimuth direction with the following factors depending on the sensor mode: High Resolution: 25 Standard: 30 Wide Swath: 15	UTM (-80° ≤ center latitude ≤ 84°) UPS (otherwise)

Table 4-2 Features of the Quick Look layers

Dataset	Sample Format	Bits per Sample	Samples per Pixel	Type Represent.	Invalid Value
Quick Look annexed to the Full resolution product	Unsigned Integer	8	1	Little Endian	0

Table 4-3 Data type for Quick Look layers

4.2.5 Ancillary information organization

The attributes to be appended (in terms of HDF5 Attributes) to the KOMPSAT-5 SAR standard products, depending on the processing Level (from Level 0 up to Level 1D) are listed in the “KOMPSAT-5 SAR Products Attributes” For each attribute the corresponding HDF5 storage structure is reported.

5. REGULATION GOVERNING IMAGE DISTRIBUTION

5.1 Copyright

In brief, copyright covers a certain number of rights granted to the author of an original work, whether scientific or artistic in nature, which are added to the usual right of ownership. At least under the copyright laws of the Republic of Korea, these rights are granted exclusively and automatically.

The users of KOMPSAT-5 data acknowledge the right of KARI to copyright protection and/or protection against unauthorized use of the KOMPSAT-5 products, in accordance with the copyright laws of the Republic of Korea and applicable international agreements. The intellectual property rights related to the KOMPSAT-5 products are protected through the end-user license agreement. The user of KOMPSAT-5 data undertake to have printed the following copyright notice on all products, in such a way that KARI's copyright be plain to all “©KARI ____ (year of production), Distribution (SI Imaging Services, Republic of Korea)”

The author of a Derived Works and Products is entitled to his own copyright in return for his creative contribution. This copyright is complementary to that owned by KARI.

5.2 General Terms of Sale

When the user buys KOMPSAT-5 image and pays the current stated price, the user obtains in return one or more copies of the products requested. However, the sale is subject to the following conditions;

- The user can only use the KOMPSAT-5 products for his own private needs and is forbidden to make these products or reproductions of these products available to a third party, either on a non-paying or a paying basis, whether temporarily or permanently.
- However, KARI may grant approval to the user to sell these data and reproductions derived from them.
- All KOMPSAT-5 products (including data and derived works) must bear the indication: all “©KARI ____ (year of production), Distribution (SI Imaging Services, Republic of Korea)” and be accompanied by a note setting forth the above regulations.

Purchase of KOMPSAT-5 image gives the owner what is generally referred to as a right of private use, which includes the right to transform the image. On the other hand, any and all collective and public use is prohibited and particularly right to distribute the image.

5.3 Permitted Uses

The END-USER is permitted by KARI a limited, non-exclusive, non-transferable license:

- (a) to install the PRODUCT on as many individual computers as needed in its premises, including internal computer network (with the express exclusion of the internet, except as provided under paragraph (g) below) for the Permitted Uses under paragraphs (b) to (i) below;
- (b) to make a maximum of ten (10) copies for (I) installation of the PRODUCT as per paragraph (a) above and (II) archiving and back-up purposes;
- (c) to use the PRODUCT for its own internal needs;
- (d) to alter or modify the PRODUCT to produce VAPs and/or DERIVATIVE WORKS;
- (e) to use any VAP for its own internal needs;
- (f) to make available the PRODUCT and/or any VAP to contractors and consultants, only for use on behalf of the END-USER, subject to such contractors and consultants agreeing in writing (I) to be bound by the same limitations on use as applicable to the END-USER, and (II) to return the PRODUCT and VAP to END-USER, and to keep no copy thereof, upon completion of the contracting or consulting engagement;
- (g) to post an extract, maximum size 1024 x 1024 pixels, of a PRODUCT or a VAP on an internet site, in a JPEG format, with the following credit conspicuously displayed: "includes material © KARI ____ (year of production), Distribution (SI Imaging Services, Republic of Korea), all rights reserved" written in full. Such posting shall be used for promotion purposes only, and may in no event allow downloading of the extract posted, nor be used to distribute, sell, assign, dispose of, lease, sublicense or transfer such extract. Prior to any posting, the END-USER shall inform KARI, specifying the URL address used by END-USER: kocust@kari.re.kr;
- (h) to print any extract, maximum size 1024 x 1024 pixels, of a PRODUCT or a VAP, and to distribute such print for promotion purposes only. Such print shall include the following credit conspicuously displayed: "includes material ©KARI ____ (year of

production), Distribution (SI Imaging Services, Republic of Korea), all rights reserved" written in full;

(i) to distribute DERIVATIVE WORKS.

All rights not expressly granted by KARI under the present Article 2.1 are hereby retained by KARI.

5.4 Prohibited Uses

The END-USER recognizes and agrees that the PRODUCT is and shall remain the property of KARI, and contains proprietary information of KARI and thus is provided to the END-USER on a confidential basis.

The END-USER shall not cause any contractor or consultant engaged as per the provisions of Section 4.3(f) to, do any of the following:

(a) do anything not expressly authorized under Section 4.3; and

(b) alter or remove any copyright notice or proprietary legend contained in or on the PRODUCTS.

6. LICENSING

All KOMPSAT-5 image products are subject to the terms of an end-user license that will be provided to the user at the time of delivery. The following commercial licenses are currently available from SI Imaging Services. Certain amount of uplift will be applied to the price for Multi-user, Expand, and Enterprise license and certain amount of discount will be applied to the price for Academic license.

Table 6-1 License

License Type	User copy	Description
Standard	1~5	Permits INTERNAL use of KOMPSAT-5 image product within 1 to 5 users* as identified by the customer at the time of purchase.
Multi-user	6~10	Permits INTERNAL use of KOMPSAT-5 image product within 6 to 10 users* as identified by the customer at the time of purchase.
Expand	11~25	Permits INTERNAL use of KOMPSAT-5 image product within 11 to 25 users* as identified by the customer at the time of purchase.
Enterprise	26+	Permits INTERNAL use of KOMPSAT-5 image product within ANY users* as identified by the customer at the time of purchase.
Academic	1~5	Permits ACADEMIC use of KOMPSAT-5 image product within 1 to 5 users* as identified by the customer at the time of purchase.

- Definition of User includes
 - One private individual
 - One company or corporation but not subsidiaries
 - One state or provincial agency
 - All departments of one county government
 - All departments of one city government
 - One Non-Governmental Organization or Non-Profit Organization
 - All departments within a single educational organization within a single country
 - One International Agency(such as United Nations) and the sponsoring host nation.

7. WARRANTY INFORMATION

- SI Imaging Services warrants that it has sufficient ownership rights in the PRODUCT to make the PRODUCT available to the END-USER under the terms thereof.
- The PRODUCT is complex; SI Imaging Services does not warrant that the PRODUCT is free of bugs, errors, defects or omissions, and that operation of the PRODUCT will be error free or uninterrupted nor that all non-conformities will or can be corrected. It does not warrant that the PRODUCT shall meet the END-USER's requirements or expectations, or shall be fit for the END-USER's intended purposes. There are no express or implied warranties of fitness or merchantability given in connection with the sale or use of this PRODUCT. SI Imaging Services disclaims all other warranties not expressly provided in End User License Agreement(EULA). In case the medium on which the PRODUCT is supplied by SI Imaging Services to the END-USER is deficient, as demonstrated by the END-USER and accepted by SI Imaging Services, SI Imaging Services shall replace said medium. Any such claim for replacement shall be submitted to SI Imaging Services within seven (7) days after delivery of the PRODUCT to the END-USER.
- In no event shall KARI nor SI Imaging Services, nor anybody having contributed to the development and/or production and/or delivery of the PRODUCT, be liable for any claim, damage or loss incurred by the END-USER, including without limitation indirect, compensatory, consequential, incidental, special, incorporeal or exemplary damages arising out of the use of or inability to use the PRODUCT, and shall not be subject to legal action in this respect. The financial cumulative liability of KARI and SI Imaging Services and of anybody having contributed to developing and/or production and/or delivery of the PRODUCT is limited to distribution of the PRODUCT and shall not in any case exceed the price paid by the END-USER to purchase the PRODUCT.

SI Imaging Services, a leading solution provider for Earth observation missions, announced an agreement with Korea Aerospace Research Institute (KARI) for “Worldwide Marketing and Sales Representative of KOMPSAT-2, 3 and 5 Image data”.

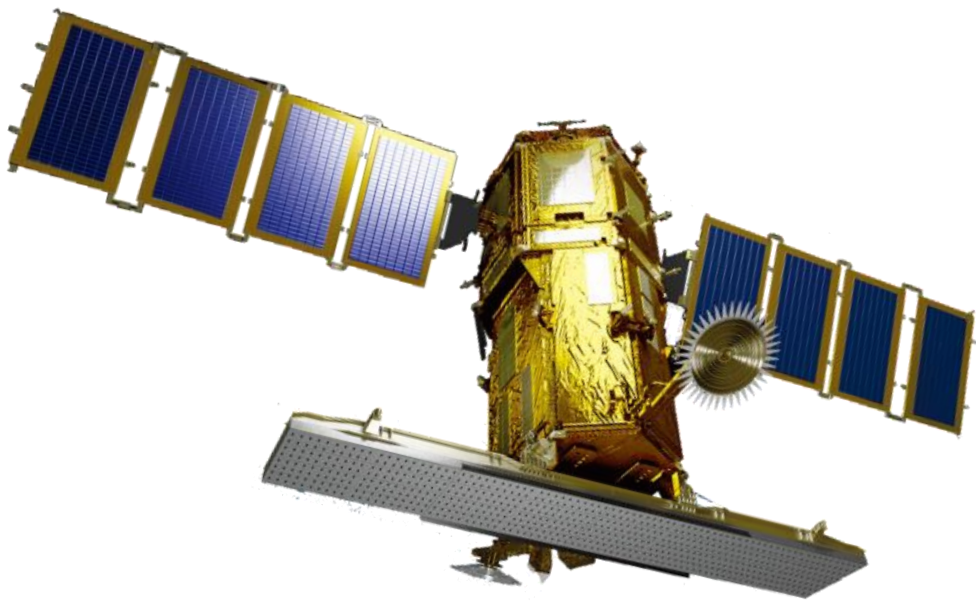

Contact:
KOMPSAT Products
sales@si-imaging.com

